

Engine 4TNV98

Engine power 46,5 kW - 63,2 HP

Operating Weight 8.300 kg

ES 85 SB

Concrete solutions. Always



 **EUROCOMACH®**

TECHNICALS SPECIFICATIONS

Operating weight (with rubber track)	kg	8.300
Operating weight (with steel track)	kg	8.620
Max travelling speed	km/h	2,6 - 5,2
Slew speed	rpm	12

ENGINE

Type		YANMAR 4TNV98
Power (2.200 rpm)	kW- HP	46,5 - 63,2
Displacement	cc	3.319
Number of cylinders	n°	4
Cooling		water
Consumption	lt/h	8,7
Alternator	V (A)	12 (40)
Battery	V (Ah)	12 (100)

HYDRAULIC SYSTEM

Circuit Type	Load sensing closed center system with flow sharing control valve	
Pump type	1 ls variable pump + 1 gear pump	
Pump displacement	cc	84 + 9
Pump capacity	lt/min	185 + 20
Max. circuit calibration pressure	bar	290 - 200 - 35
Low flow (high flow) auxiliary circuit:		
Max capacity	lt/min	40 ÷ 60 (100)
Max pressure	bar	290 (200)

PERFORMANCES

Bucket breaking force (standard arm) ISO 6015	daN	5.500
Arm breaking force (standard arm) ISO 6015	daN	4.350
Traction force	daN	7.960
Ground pressure with canopy (with rubber tracks)	kg/cm ²	0,41
Max slope		60% - 30°

DIMENSIONS

Total width	mm	2.320
Max dumping height with cab standard arm (optional arm)	mm	5.220 (5.470)
Total height	mm	2.560
Rear rotation radius	mm	1.155
Max digging depth standard arm (optional arm)	mm	3.800 (4.150)
Digging arm length std (optional)	mm	1.760 (2.110)
Tracks width	mm	450
Rollers number (for each side)	n°	5/1 (rubber track) 6/1 (steel track)

FILLINGS

Fuel tank	lt	105
Hydraulic oil tank	lt	90
Hydraulic circuit capacity	lt	120
Cooling system capacity	lt	25
Engine oil	lt	10

CONTROLS

Boom, dipper stick, bucket and turret swing	2 pilot joysticks
Tracks movement (included counter rotation)	2 pilot levers
Dozer blade	1 pilot lever
Auxiliary circuit (simple or double effect)	electroproportional switch on right joystick

ES 85 SB

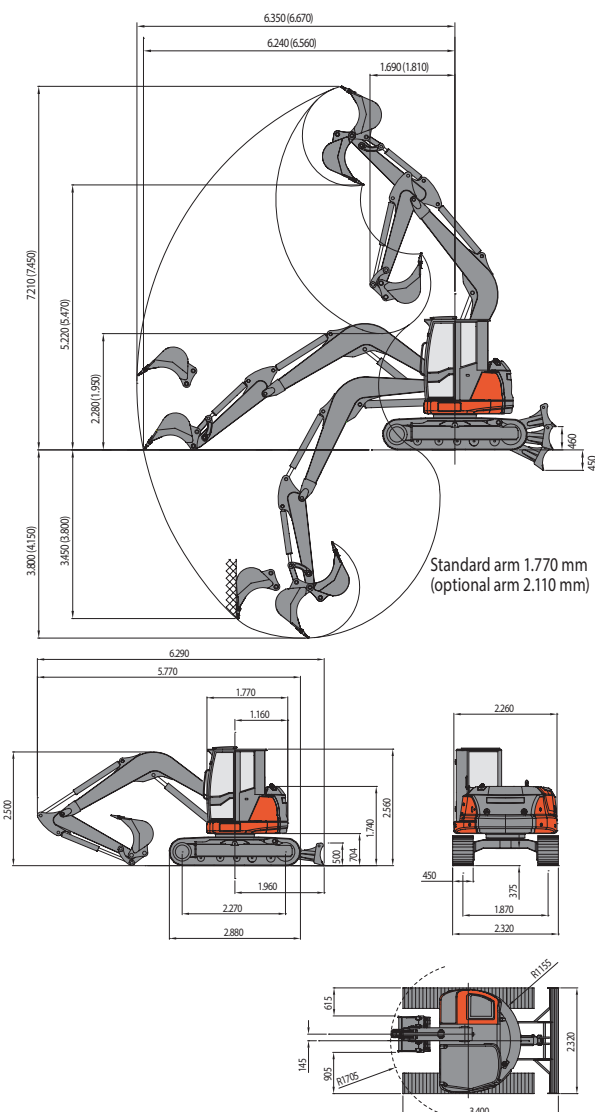

LIFTING CAPACITY				
Opening arm from the rotation's center (m)				
Lifting capacity (kg) at 1.5 m height				
	3	4	5	MAX
Frontal and lowered dozer blade	4270	3130	2540	2390
Frontal and lifted dozer blade	3282	2070	1485	1340
Lateral	2859	1827	1292	1140

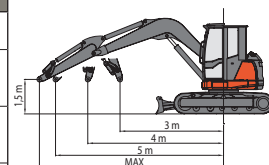

The lifting capacity is based on the ISO 10567 and it does not exceed more than the 75% of static tipping load or more than the 87% of the hydraulic lifting capacity of the machine.



EUROCOMACH®

MADE IN ITALY

Sampierana S.p.a.

47021 S.Piero in Bagno (FC)

via Leonardo da Vinci, 40

Tel +39 0543.904211

Fax +39 0543.918520

www.eurocomach.com